

APEX62 LPG / Diesel / Electric

(6300.13 / 6300.23 / 6300.33)

Training
Troubleshooting
Adjustments
Components/Suppliers

APEX62 LPG / DIESEL / ELECTRIC	1
1.0 OPERATION	5
1.1 Scheme of Operation.....	6
2.0 TECHNICAL DATA	7
3.0 DESIGN AND MECHANICS	11
3.1 Operation Elements.....	12
3.2 Cylindrical Broom and Side Brush	13
3.2.1 Cylindrical Broom	13
3.2.1.1 Replace Cylindrical Broom	13
3.2.1.2 Check Sweeping Mark Distance	14
3.2.1.3 Adjust Sweeping Mark Distance	14
3.2.2 Side Brush	15
3.3 Dirt Hopper ABBA System.....	17
3.4 Dirt Hopper Lift-Out System	19
3.5 Filter	20
3.5.1 Change and Clean Cartridge Filter	20
3.5.2 Suction Fan Flap	20
3.6 Steering	21
3.7 V/D-Version Travelling Drive	22

3.8 E-Version Travelling Drive	23
3.8.1 Bearing Plate.....	23
3.8.2 Change Wheel.....	24
4 DRIVE	25
4.1 LPG-Version Engine	26
4.1.1 Engine.....	26
4.1.2 LPG Version.....	28
4.2 Diesel-Version Engine	31
5 HYDRAULIC SYSTEM	33
5.1 General	34
5.2 Brief Description of Combustion Engine Travel Drive	34
5.2.1 Hydraulic Diagram Combustion Engine Driving.....	35
5.2.2 Drive Pump.....	36
5.3 Brief Description of Work Hydraulic	37
6 ELECTRICAL SYSTEM	38
6.1 Safety Information	39
6.2 View on Combustion Engine Fuse Box	40
6.3 View on E-Version Fuse Box	42
6.4 Seat Contact Controller	44
6.4.1 Circuit Diagram.....	44
6.4.2 Logic.....	45

6.5 Drive Controller	46
6.5.1 Error Messages	48
6.5.2 Machine Safety Functions	49
6.6 Electric Drive Motor	50
6.7 Low Discharge Signal Sender (LDS)	51
6.7.1 LDS Setting Mode	51
6.7.2 LDS Programming.....	53
7 MAINTENANCE	55
7.1 LPG-Version Service Intervals	56
7.2 Diesel-Version Service Intervals	58
7.3 E-Version Service Intervals	60

1.0 Operation

1.1 Scheme of Operation

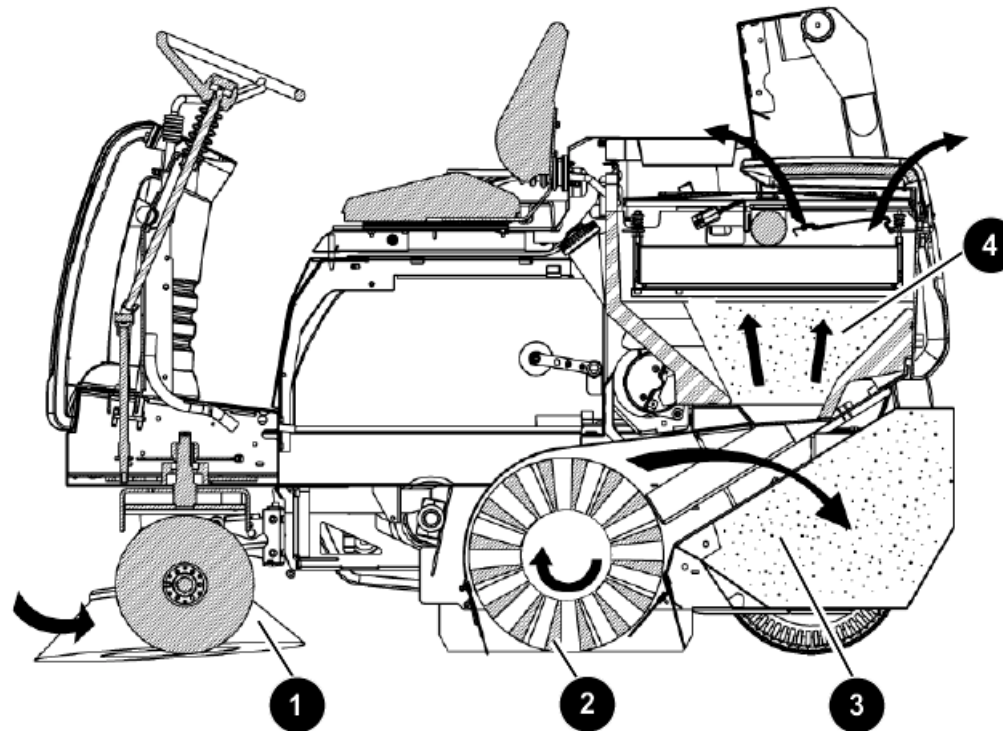

Functional details: The side brush (1) removes dirt from corners and edges and allows enlarging work width and area performance on free surfaces. The cylindrical broom (2) collects the dirt to throw it overhead into the dirt hopper (3). The collected fine dust is drawn in by suction fan and separated by the filter system (4). Clean air only is taken out into the environment. Disposal of dirt is realized via high-dump system directly into a standard dustbin.

2.0 Technical Data

		APEX62 LPG	APEX62 Diesel	APEX62 Electric
Dimensions and weights				
Length incl. side brush	mm	1,998	1,998	1,998
Width w/o side brush	mm	1,142	1,142	1,142
Width with 1 side brush	mm	1,142	1,142	1,142
Width with 2 side brushes	mm	1,142	1,142	1,142
Height above driver seat	mm	1,520	1,520	1,520
Empty weight	kg	763	784	1,105
Adm. total weight	kg	1,056	1,074	1,395

Riding and sweeping performance				
Forward driving speed	km/h	0 – 9	0 – 9	0 - 8
Wheel speed at max. velocity	rpm	156	156	139
Reverse driving speed	km/h	0 – 4	0 – 4	0 - 4
Wheel speed at max. velocity	rpm	58	58	58
Max. sweeping speed (recommended: 4.0 km/h)	km/h	9.0	9.0	8.0
Sweeping width with/w/o side brush	mm	850 / 1,150	850 / 1,150	850 / 1,150
Sweeping width with 2 side brushes	mm	1,470	1,470	1,470
Theor. sweeping performance with 1 / 2 side brush(es)	m ² /h	10,300 / 13,200	10,300 / 13,200	9,200 / 11,700
Climbing ability	%	18	18	16

Filter system				
Filter surface	m ²	4.8	4.8	4.8
Plate filter	qty.	1	1	1

		APEX62 LPG	APEX62 Diesel	APEX62 Electric
Cylindrical broom				
Length / diameter	mm	800 / 430	800 / 430	800 / 430
Wear limit	mm	350	350	350
Speed	rpm	500 ± 20	500 ± 20	500 ± 20
Distance between sweeping marks	mm	70 + 10	70 + 10	50 + 5
Qty. of bristles	qty.	12 V-shape	12 V-shape	12 V-shape
Standard bristling		PA	PA	PES

Sealing strip ground clearance (broom compartm.)				
left / right / rear	mm	1 / 1 / 4	1 / 1 / 4	1 / 1 / 4
front	mm	0	0	0

Side brush				
Diameter	mm	600	600	600
Speed	rpm	85	85	85
Standard bristling		PA	PA	PE

Dirt hopper				
Hopper volume	l	130	130	130

Wheels				
Front wheel drive (solid rubber)		4.00-4	4.00-4	4.00-4
Rear wheels (pneumatic)		4.00-8	4.00-8	
Inflation pressure	bar	6	6	
Optional rear wheel option (solid rubber) (Standard E)		4.00-8	4.00-8	4.00-8

Service Manual



		APEX62 LPG	APEX62 Diesel	APEX62 Electric
Engine				
Manufacturer		Briggs&Stratton	Lombardini	
Type		Vanguard V-Twin	LDW 502	
Work cycles / quantity of cylinders		4-stroke / 2	4-stroke / 2	
Capacity	cm ³	480	505	
Power (at 2,550 rpm)	kW	8.2	6.3	
Service speed (all consumers on)	rpm	2,550 + 50	2,550 + 50	
Fuel tank capacity	l	25	25	
Consumption	l/h	2.5	1.25	
Engine oil / filling	Type / l	15W-40 / 1.5	15W-40 / 1.5	
Spark plug		Champion RC 12 YC		

Hydraulic system				
Hydraulic fluid (e.g. Mobiloil)		DTE 15 M	DTE 15 M	DTE 15 M
Tank capacity	l	22	22	13

Electrical system				
Starter battery	V / Ah	12 / 74	12 / 45	(24 / 240 od 420)
Generator	A	13	13	
Total output	kW			1.90
Output of drive motor	kW			0.85
Output of hydraulic drive	kW			1.00

Noise emission value				
Sound pressure level acc. to DIN IEC 60335-2-72	dB(A)	78	79	71
Sound power level acc. to DIN IEC 60335-2-72	dB(A)	94	95	88

3.0 Design and Mechanics

3.1 Operation Elements



The spring (carrier spring) connected to the side broom lever should be slightly under tension. The tension must not exceed the tension of the valve-neutral-spring (hydraulic valve).

3.2 Cylindrical Broom and Side Brush

3.2.1 Cylindrical Broom

3.2.1.1 Replace Cylindrical Broom

Dismounting:

- Lower broom
- Remove l-h lateral cover
- Loosen star-shape knob (2) to remove l-h broom arm (1)
- Open both knobs (3+5) and remove lateral plate (4); pull out the cylindrical broom



Mounting:

Proceed in inverse order

Note:

Twist broom while inserting until it audibly catches in the driving tooth



3.2.1.2 Check Sweeping Mark Distance

- Take machine to level concrete or asphalt ground (check inflation pressure of machines equipped with pneumatic tyres and correct pressure if required)
- Switch on cylindrical broom and let it run briefly while vehicle is standing
- Lift up and switch off the cylindrical broom, forward machine a short distance and measure dimensions of sweeping marks

With correct adjustment of the cylinder broom, the marks left on the ground have to be in parallel. The distance between parallel sweeping marks of the APEX62 Electric should amount to 50 + 5 mm, that of the other APEX62 to: 70 +10 mm.

Note: Exceeding the specified width has a negative effect on the service life of the cylindrical broom.
The distances between marks reduce as the cylinder broom diameter reduces due to bristle wearing.

3.2.1.3 Adjust Sweeping Mark Distance

Adjust the sweeping mark distance by turning the hand wheel located under the engine compartment cover. The “mark pin” indicates wear limit of the cylindrical broom.



Adjusting parallelism

- Loosen l-h half-bearing of torsion shaft
- Adjust parallelism with stop screw

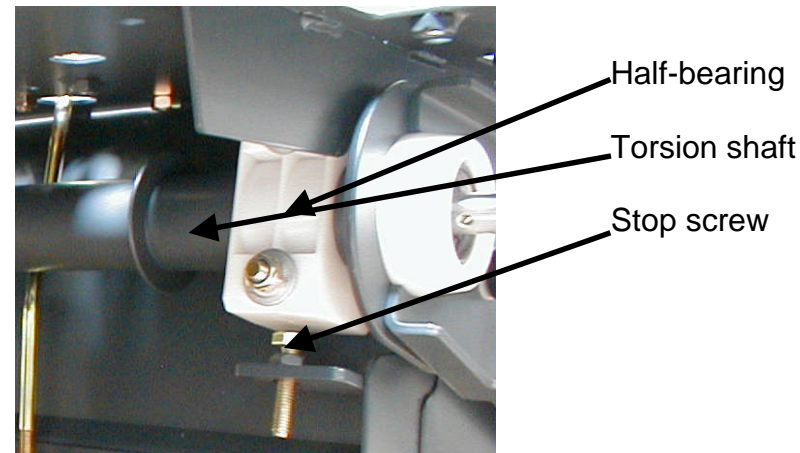

3.2.2 Side Brush

Provide for side brush inclination such that the contact surface covers about $\frac{2}{3}$ of the brush circumference.
Seen in direction of travel, the floor contact surface of the r-h side brush should be between the **11** and **3** o'clock position.
l-h side brush between the **9** and **1** o'clock position

- Adjust height of the lifted-out side brush at the cable cord such that the alignment of the top belt pulley borders is about 10° below horizontal level. This results in a clearance between upper V-belt side and lateral cover holder of approx. 15 mm.
- V-belt tension cannot be adjusted but is ensured by spring force.

Height adjustment



Inclination of 5° fixed

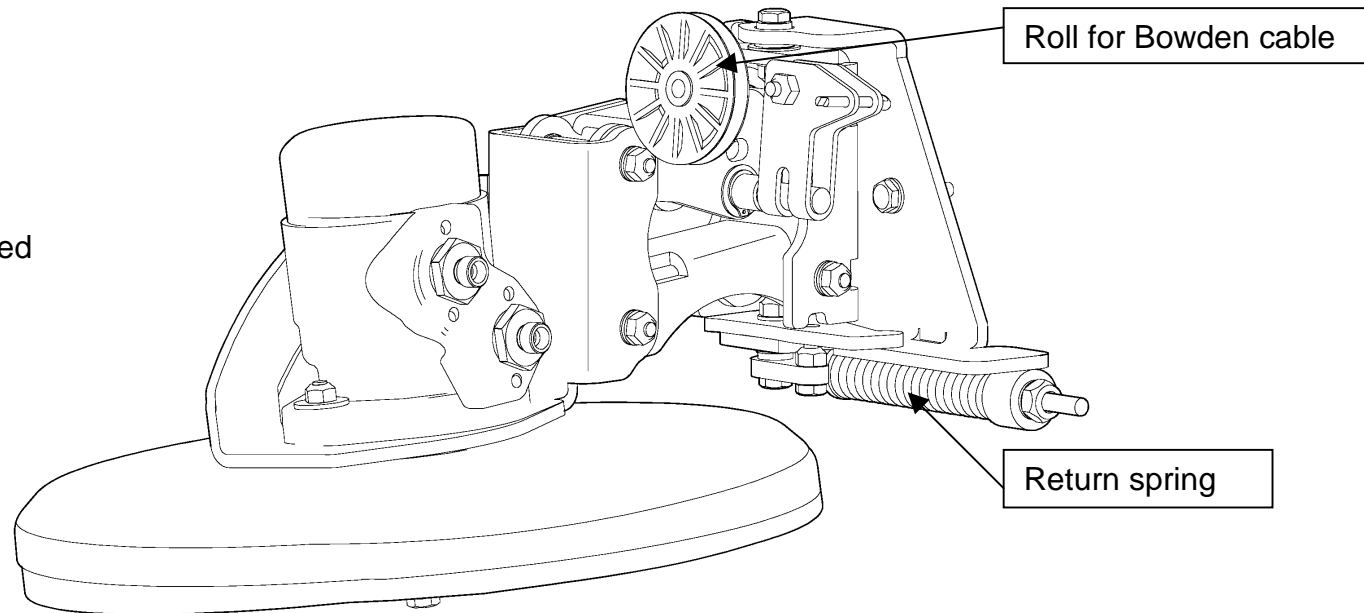

3.3 Dirt Hopper ABBA System

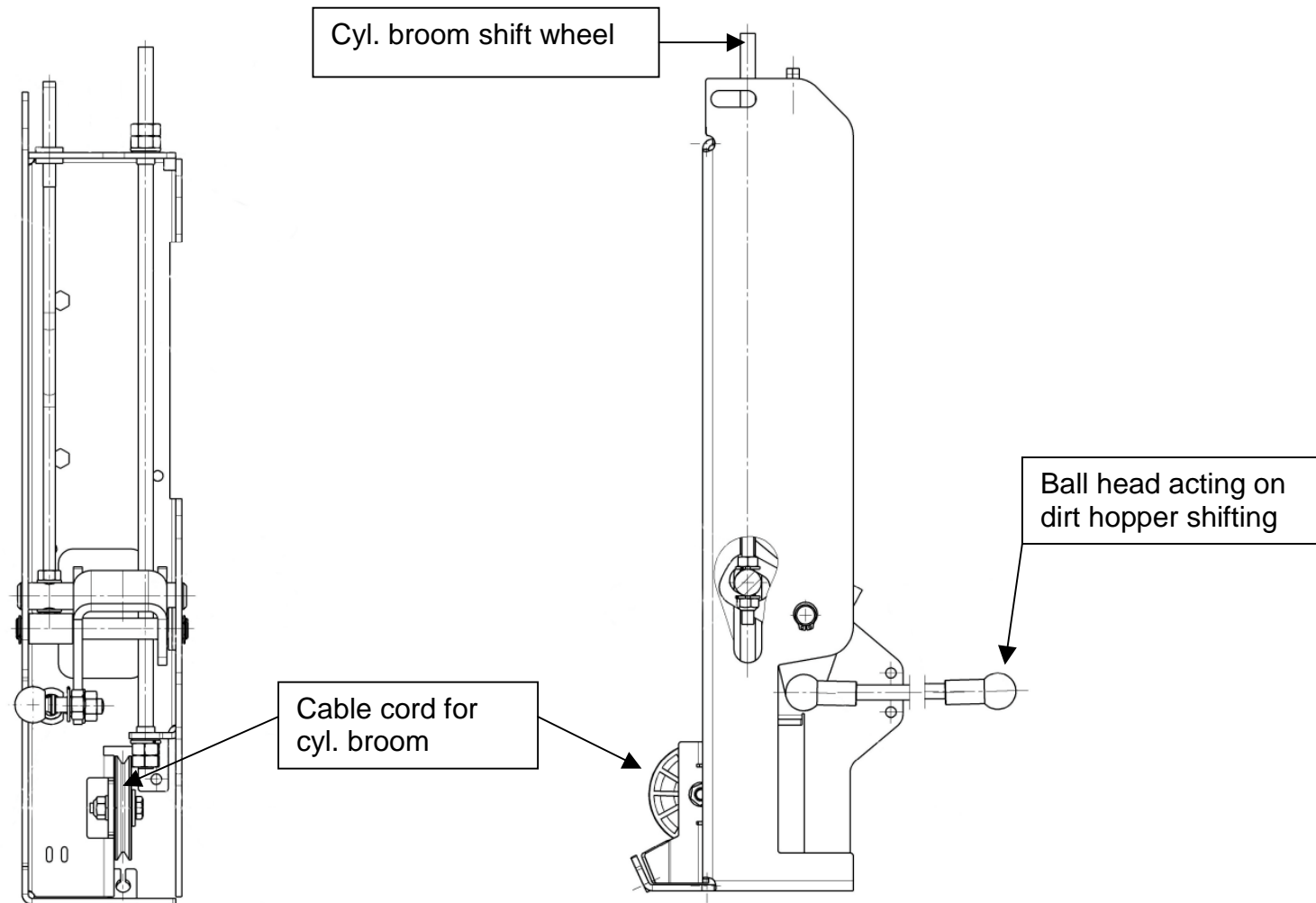

Tracking of the Dirt Hopper

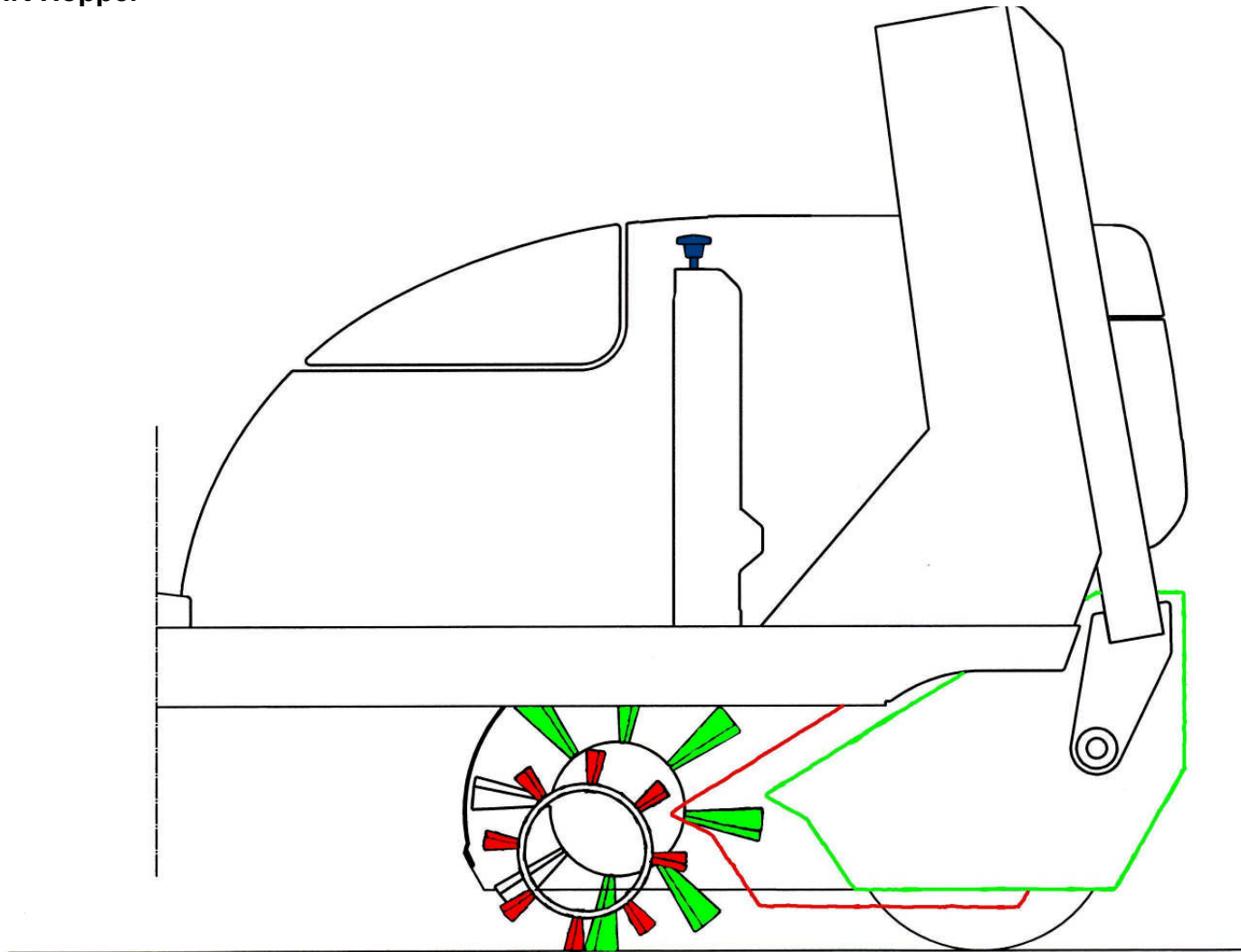

3.4 Dirt Hopper Lift-Out System

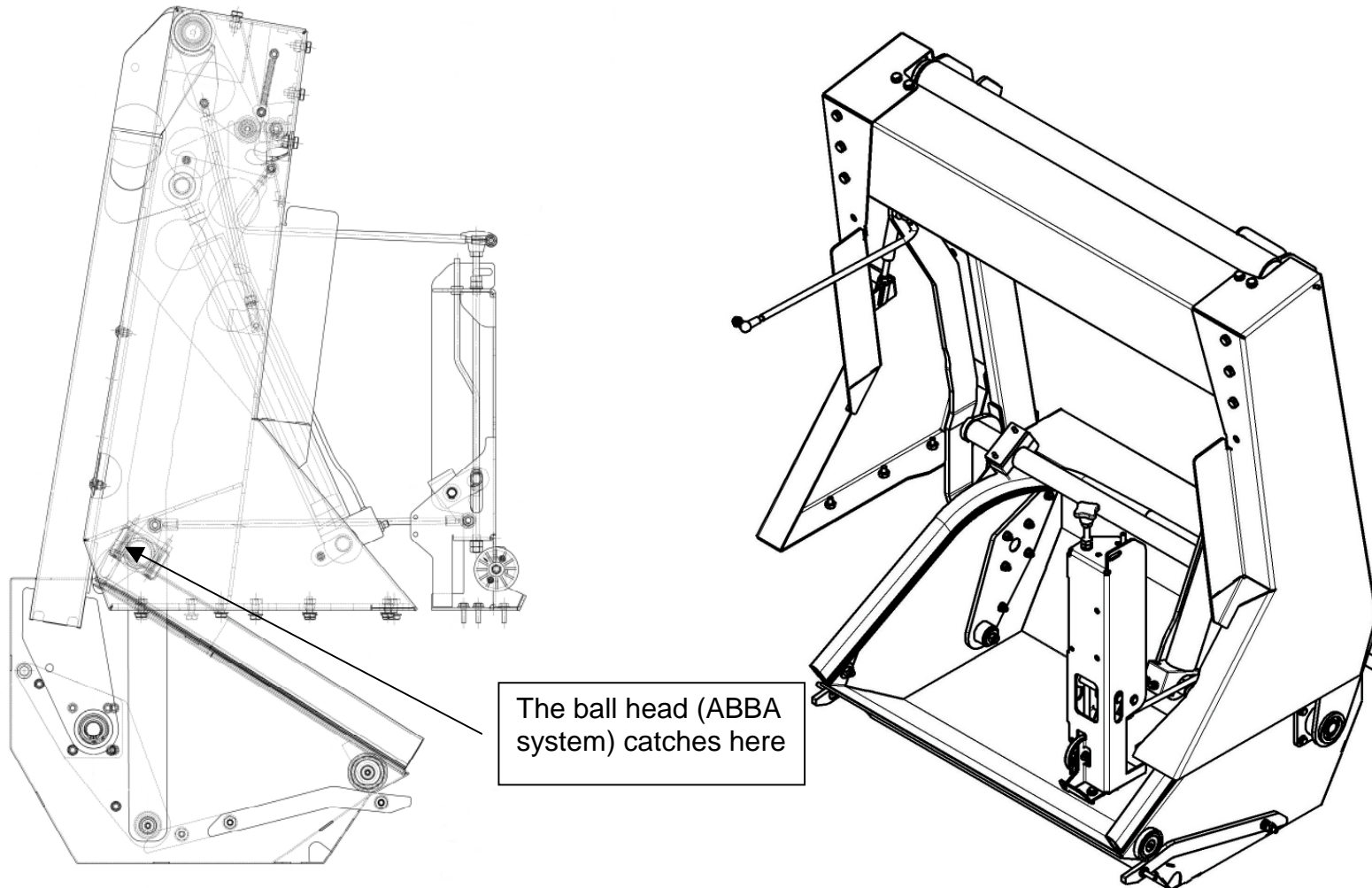

3.5 Filter

3.5.1 Change and Clean Cartridge Filter

- Stop engine and pull key
- Open seat hood
- Remove filter case cover
- Loosen and remove wing screws at the corner points
- Fold up and hook jolter frame
- Remove cartridge filter by pulling to top

3.5.2 Suction Fan Flap

- Before collecting wet dirt or sweeping humid surfaces, change over the flap position (from filter passage to direct air flow position). Change over by pulling the knob on the dashboard.
- Use switch (S12) at the control wire below the dashboard to actuate the jolter motor.

Note: Driven by a V-belt, the fan constantly runs as soon as the engine is running.

3.6 Steering

- Open maintenance flap
- Compression spring with nut: turn jointly until a clearance of 0.2mm remains between the coil spaces (feeler gauge)

Representation of the APEX49!
Carrier plate changed,
no cover plate

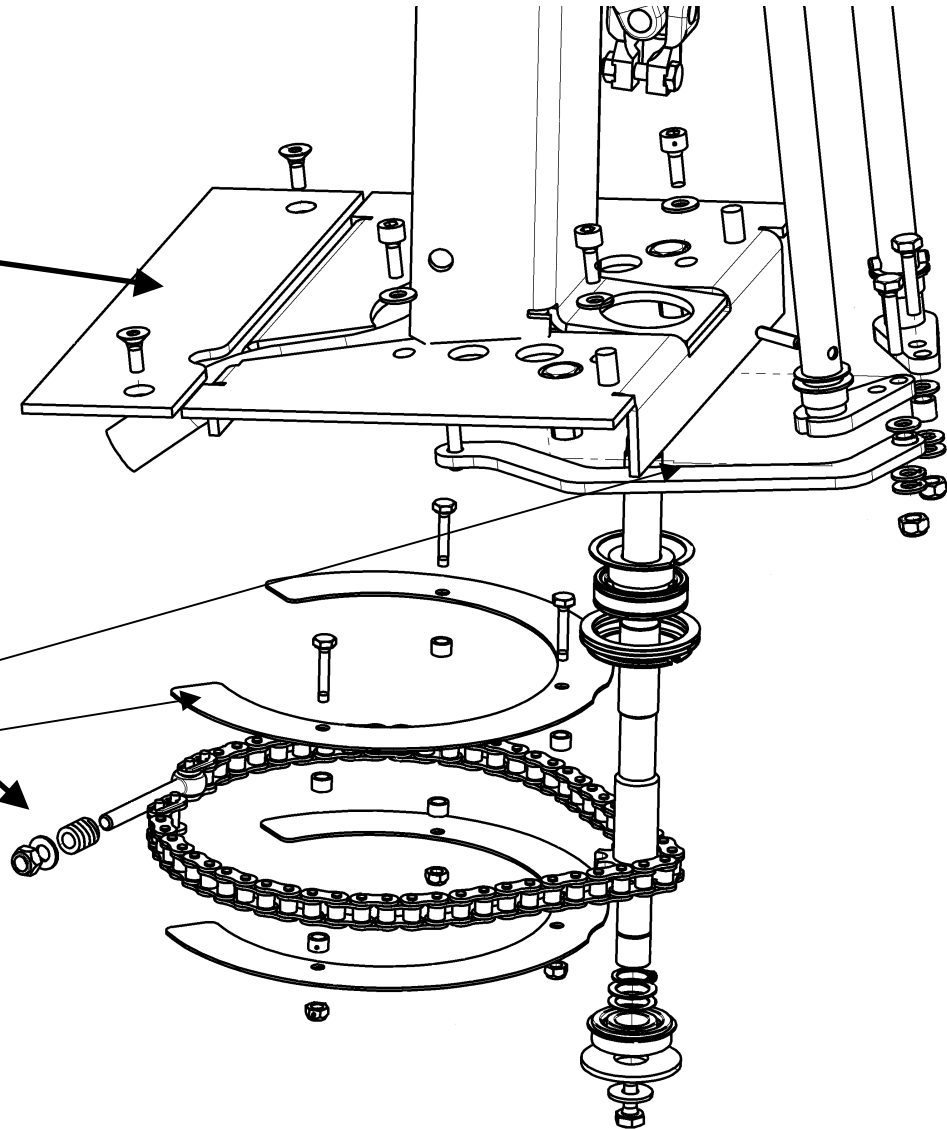

3.7 V/D-Version Travelling Drive

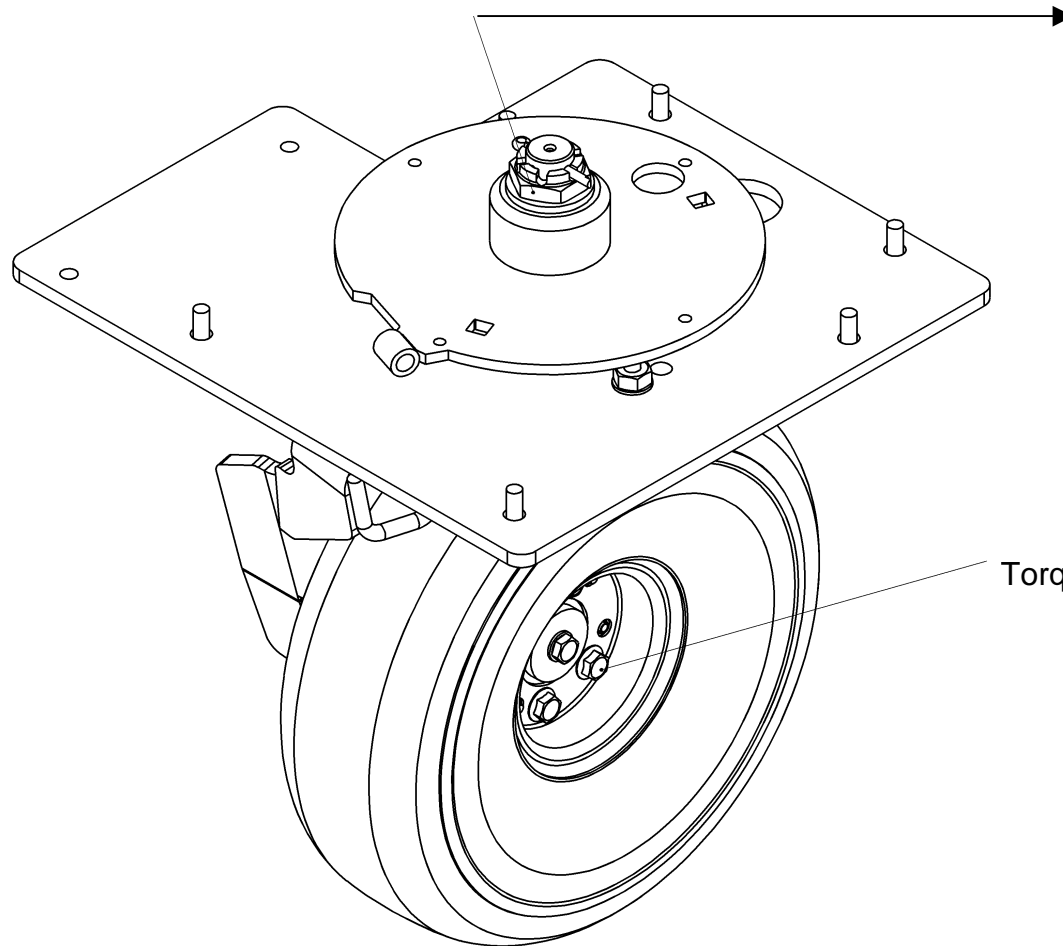

- Tighten nut by 60 Nm with simultaneous swinging of the wheel
- Loosen nut
- Tighten nut by 20 Nm
- If split pin holes do not match tighten nut until next split pin hole

Torque 32 Nm

3.8 E-Version Travelling Drive

3.8.1 Bearing Plate

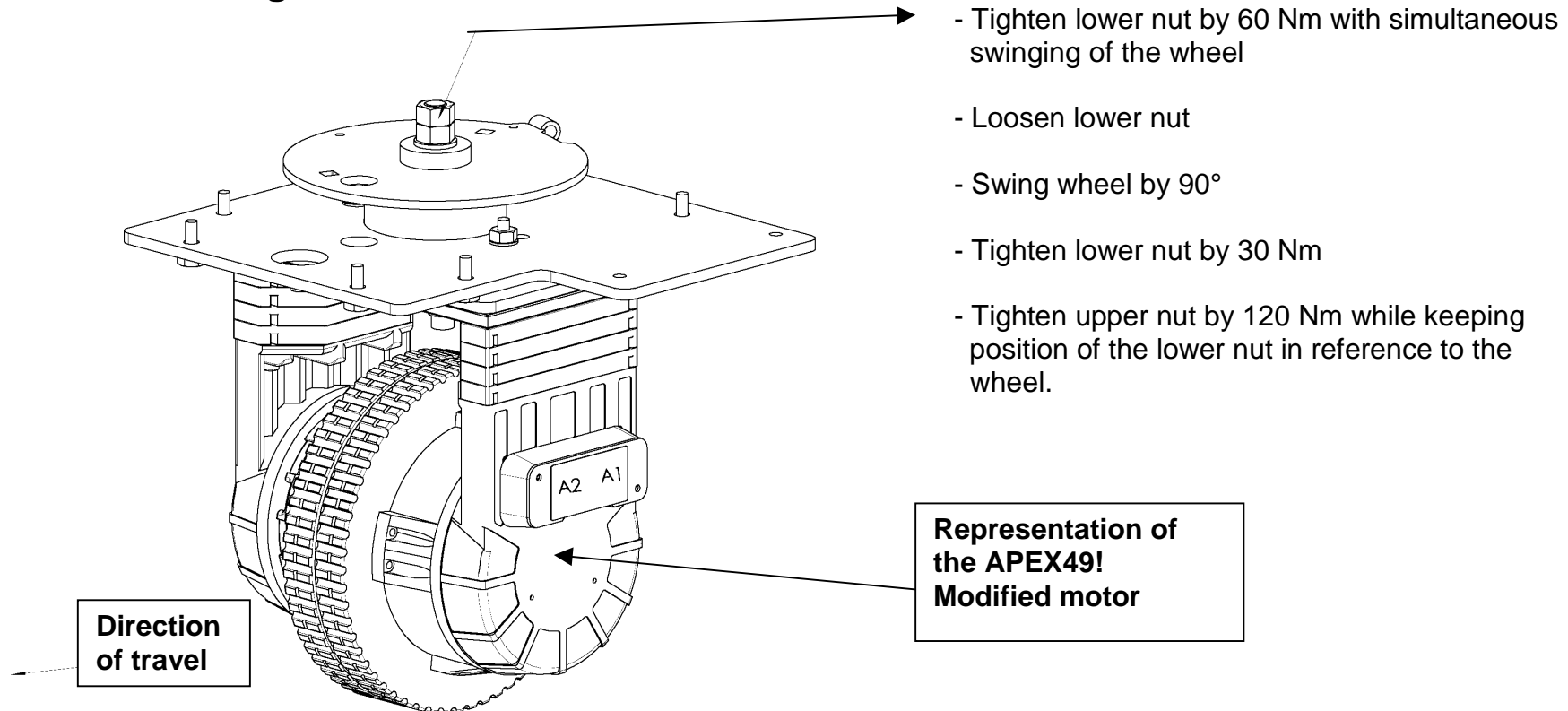

3.8.2 Change Wheel

Removal and fitting stages required for replacement of the wheel

4 Drive

4.1 LPG-Version Engine

4.1.1 Engine

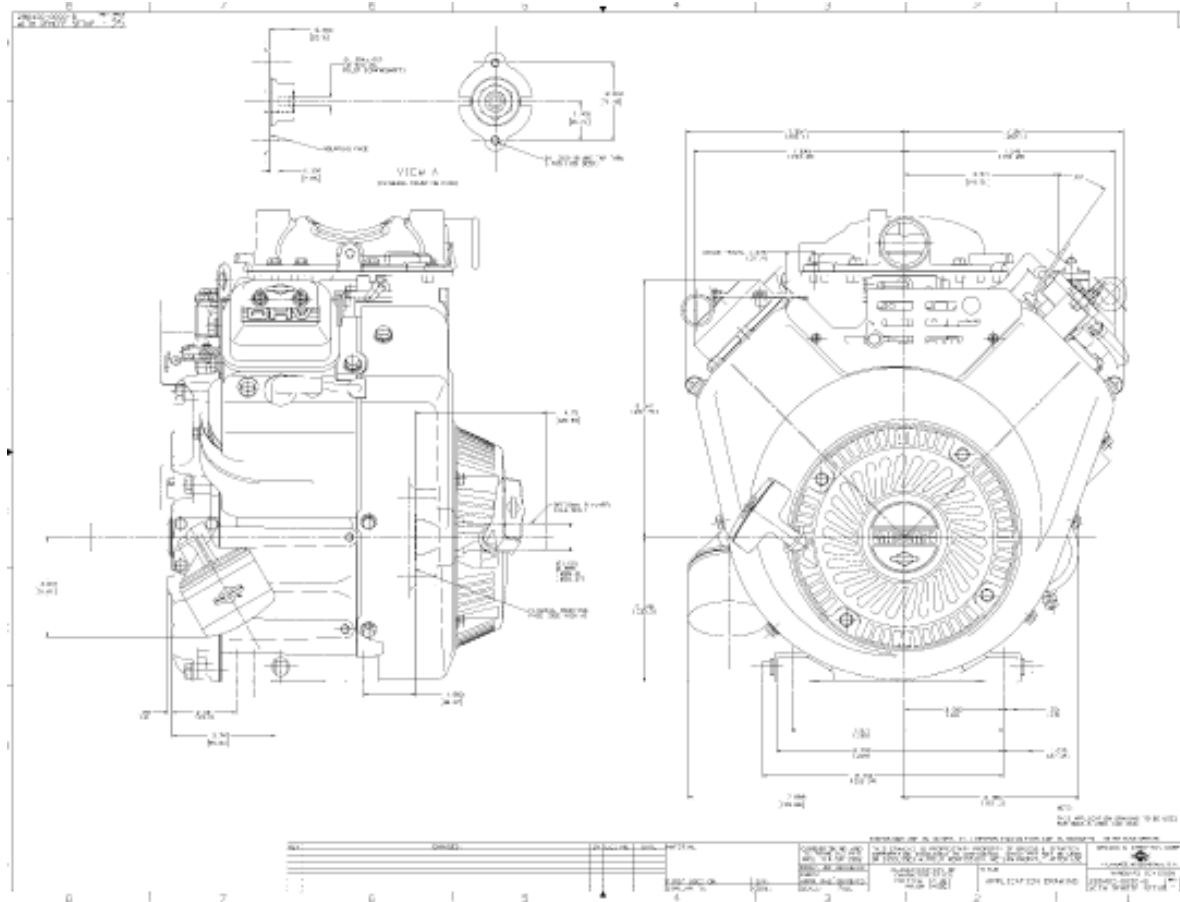

Air-cooled, 2-cylinder, 4-stroke petrol engine with 11.93 kW at 3,600 rpm with electrical starter

Manufacturer: Briggs & Stratton

Type: Vanguard V-Twin 16HP

Nominal speed: (cyl. broom, side brush and suction fan being on)	2,500 rpm
Upper idling speed:	2,650 ± 50 rpm
Lower idling speed:	1,550 ± 50 rpm
Capacity:	480 ccm
Output at nominal speed:	8.2 kW
Torque at 2,400 rpm:	33.1 Nm

Maintenance and repair of the drive units

according to manufacturer's prescriptions

4.1.2 LPG Version

Construction scheme

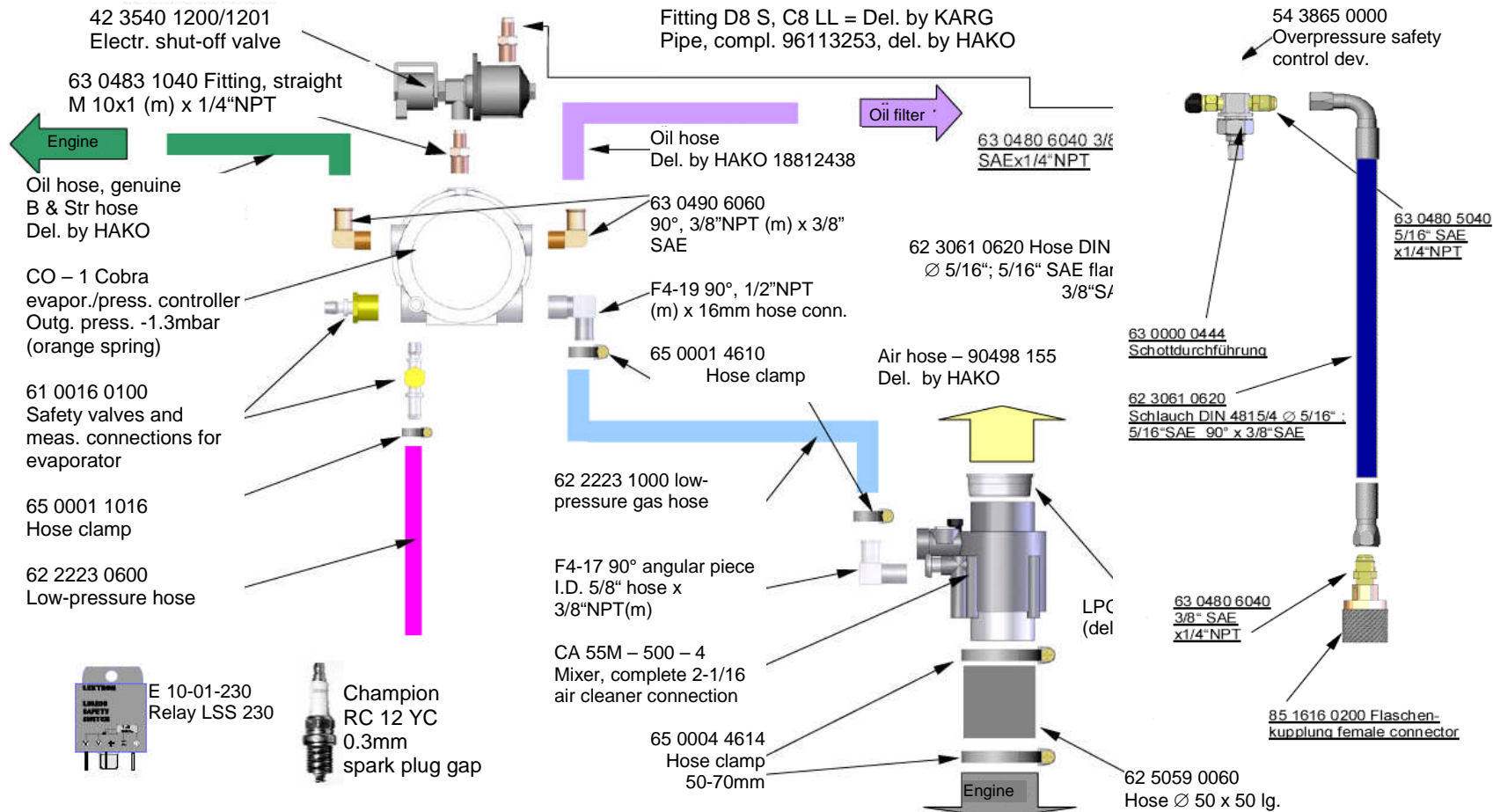

- 1) Check position of gas cylinder for liquid discharge; base plate protrudes the cylinder collar opening.
- 2) The LPG system is to be checked for leakage by pressure test
- 3) Check throttle for central position
See Fig. 7
- 4) For correct CO measurement, the following is required:
 - a) Insert exhaust gas measurement probe for at least 300 mm into the tailpipe and secure.
 - b) Bridge plug at seat contact switch.
- 5) Start engine
- 6) Take to service temperature; in idle run (1,550 +50 1/min) CO should amount to < 0.1 % otherwise regulate via mixture control screw, see Fig. 6
- 7) If required, remove pipe adapter, measurement probe and bridge of seat contact switch. Re-install connection of seat contact switch and secure by shrinking hose

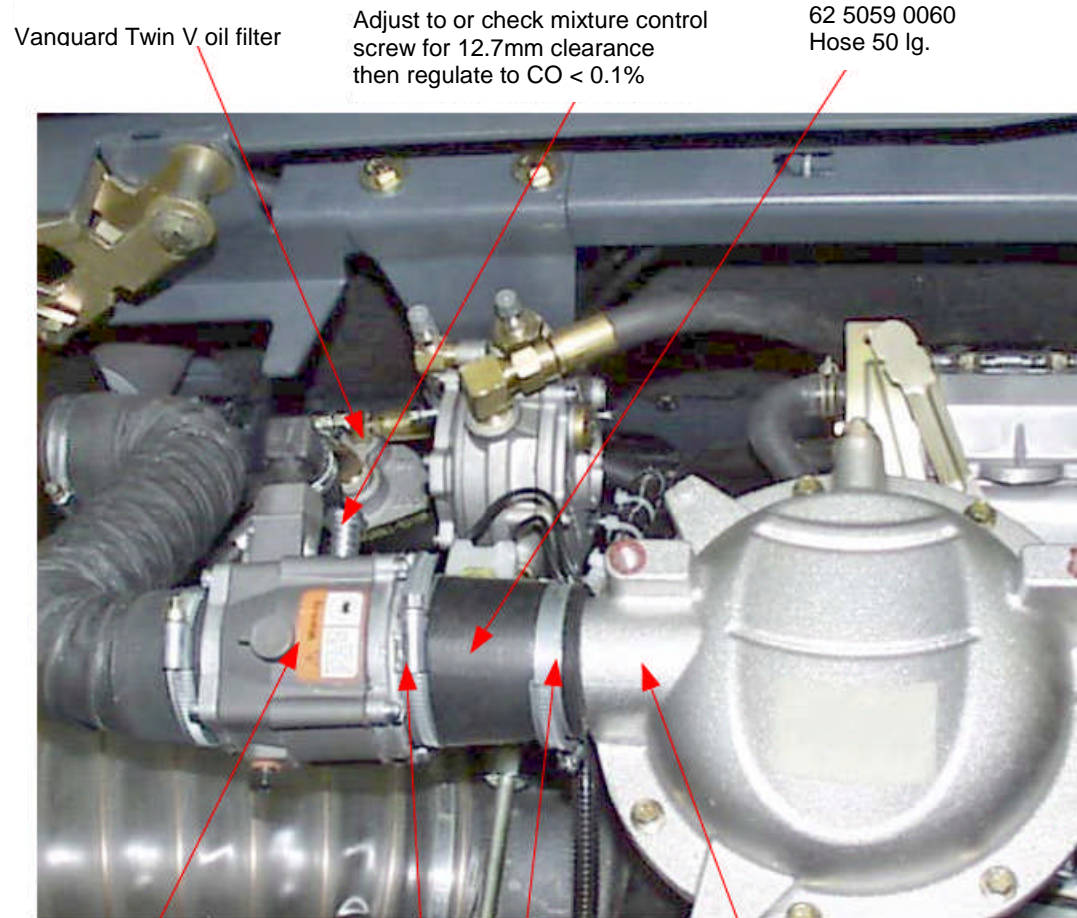

Fig. 6

CA 55M – 500 – 4
Mixer, complete

65 0004 4614
Hose clamps

Vanguard-Twin V
Carburettor connection

Adjust to or check mixture control
screw for 12.7mm clearance
then regulate to CO < 0.1%

62 5059 0060
Hose 50 lg.

Set throttle
to neutral (central) position
or check for central position

Air hose (Hako)
90490970
Hose clamp A 40 – 60
17533027

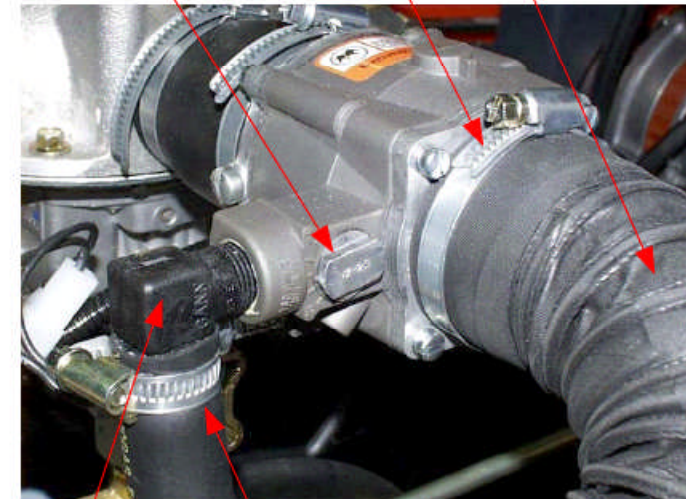

Fig. 7

F 4 – 17
90° angular flange,
ID, 5/8" x 3/8" NPT(m)

65 0001 4610
Hose clamp +

62 2223 1000
Low-pressure gas hose

4.2 Diesel-Version Engine

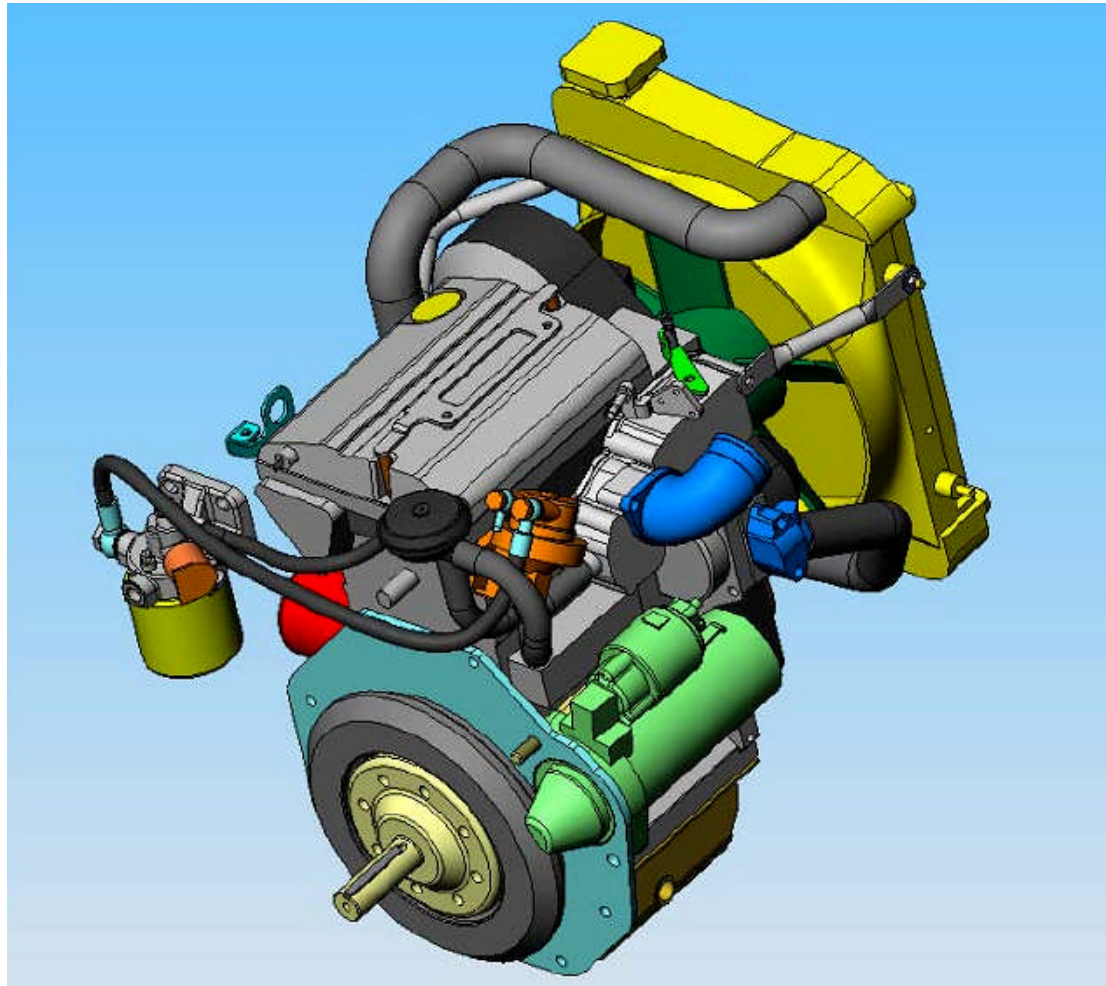

Service Manual



Water-cooled, 2-cylinder 4-stroke diesel engine with 9.8 kW at 3,600 rpm with electrical starter

Manufacturer: Lombardini

Type: LDW 502

Nominal speed:	(cyl. broom, side brush and suction fan being on)	2,550 rpm
Capacity:		505 ccm
Bore:		72 mm
Stroke:		62
Compression ratio:		22.8: 1
Output at nominal speed:		8.2 KW
Torque at 2,000 rpm:		28 Nm

Maintenance and repair of the drive units

according to manufacturer's prescriptions

5 Hydraulic System

5.1 General

Hydraulic units are maintenance-free.

Maintenance reduces to oil and filter change in the sense of system cleaning.

Regular inspection and periodic maintenance precludes premature failure.

5.2 Brief Description of Combustion Engine Travel Drive

The machines with IC engines are equipped with hydrostatic travel drives which operate in closed systems.

Forward and reverse driving speed is continuously controllable by pedal, mechanically on the pump. Due to automatic return to zero position, the machine is dynamically slowed down and self-retaining against unwanted rolling of the machine.

Should moving of the machine be necessary when engine stands still, open the bypass valve of the pump.

Pump pressure is assured by two pressure-limiting valves (bidirectional). They are set to 160bar (forward) and 130 bar (reverse).

5.2.1 Hydraulic Diagram Combustion Engine Driving

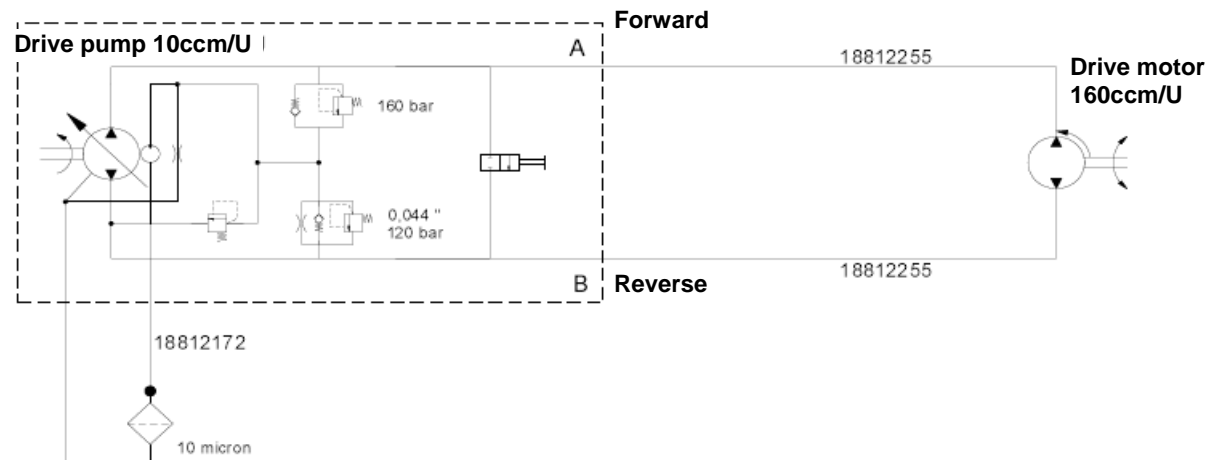

As soon as the engine runs, the feed pump delivers hydraulic fluid into the driving circuit. The fluid is available in the complete circuit and comes in at the pressure-limiting valves (forward and reverse) as well as at the feed pressure valve. Since feed pressure adjustment is the lowest, this valve opens and the driving circuit features a pressure of 3.8bar + 0.2bar when the engine is running. When the drive pump is mechanically shifted to forward (A) or reverse mode (B), a fluid circulation into the specific direction is generated and, depending on the drive motor resistance, a driving pressure builds up in the circuit. After this pressure attains the 160bar (forward) or the 130bar (reverse), the pressure-limiting valve opens accordingly and protects driving.

5.2.2 Drive Pump

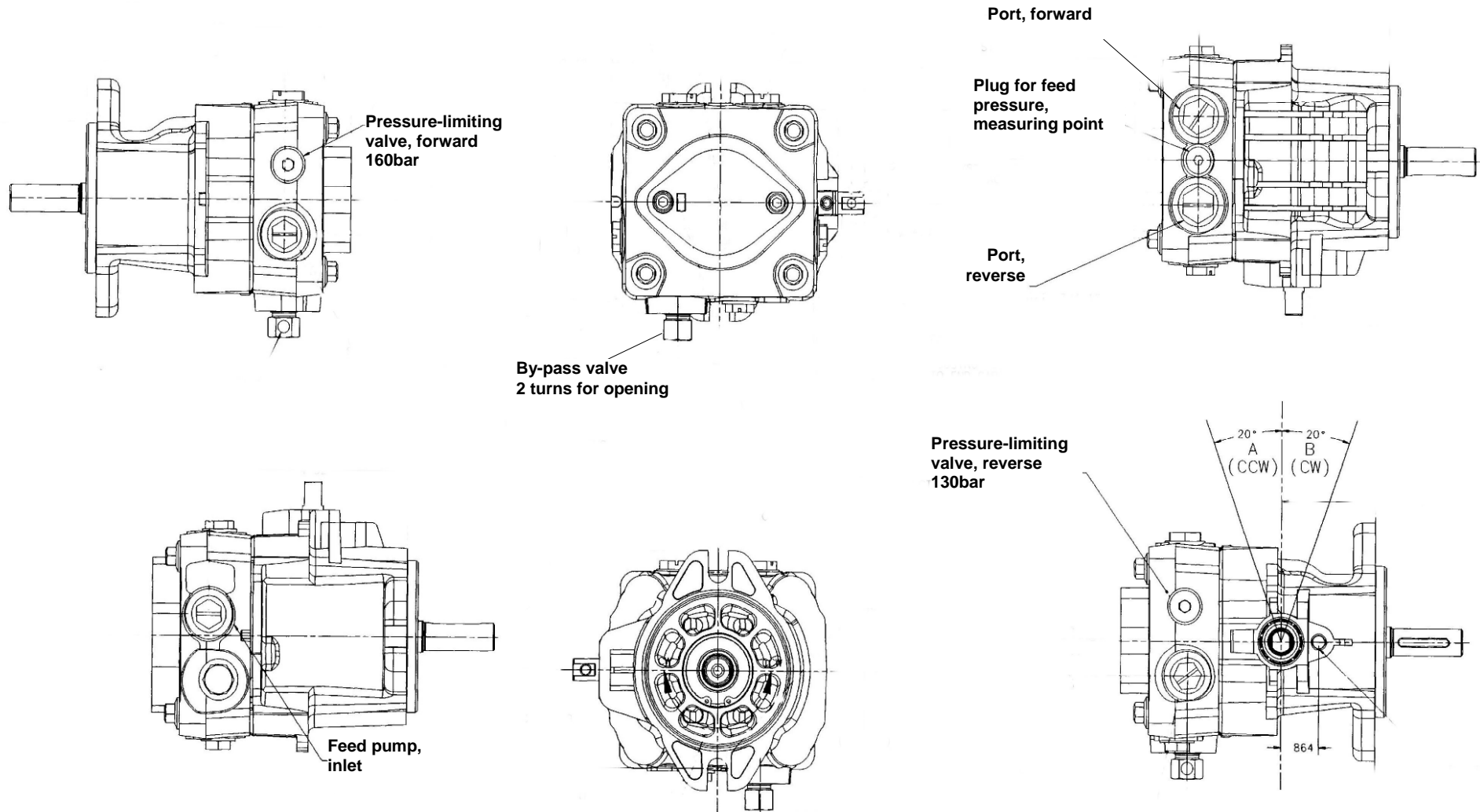

5.3 Brief Description of Work Hydraulic

Work hydraulic is responsible for supply of the side brushes and the lifting cylinder of the hopper lift-out system.

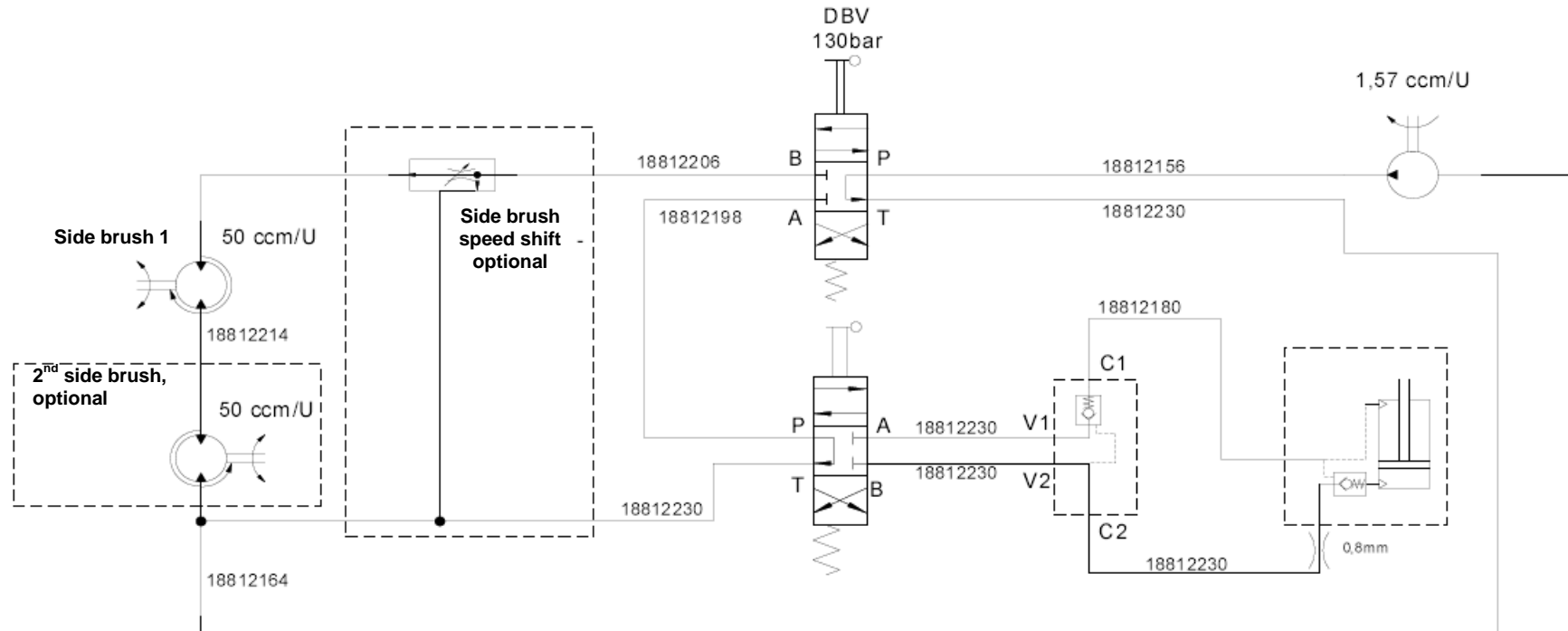

A gear pump (driven by V-belt) delivers hydraulic fluid from the tank to the combined control valve. As long as no specific function is set, the fluid flows back into the tank. For operation of side brush, the “upper” partial valve is shifted downwards by actuation of the side brush lever to allow the fluid flowing to the side brush motors for driving them. For emptying of the dirt hopper, a safety circuit (two-hand operation) is provided for which the “upper” partial valve has to be switched upwards by the broom cylinder operating lever while, simultaneously, the hopper lever allows switching of the “lower” partial valve upwards. Then the fluid flows from the pump through the “upper” to the “lower” and then to the piston side of the lifting cylinder. The hopper is then lifted-out. For lowering, actuation of the hopper lever to the other side (valve switched downwards) is sufficient.

6 Electrical System

6.1 Safety Information

Caution!

- Before working at the engine and at the electrical system, generally disconnect the battery (negative pole).

Information for AC generator

- Let engine run only with the battery connected.
- Do not use the charger unit for emergency starting
- Disconnect battery before re-charging or electro-welding at the machine

6.2 View on Combustion Engine Fuse Box

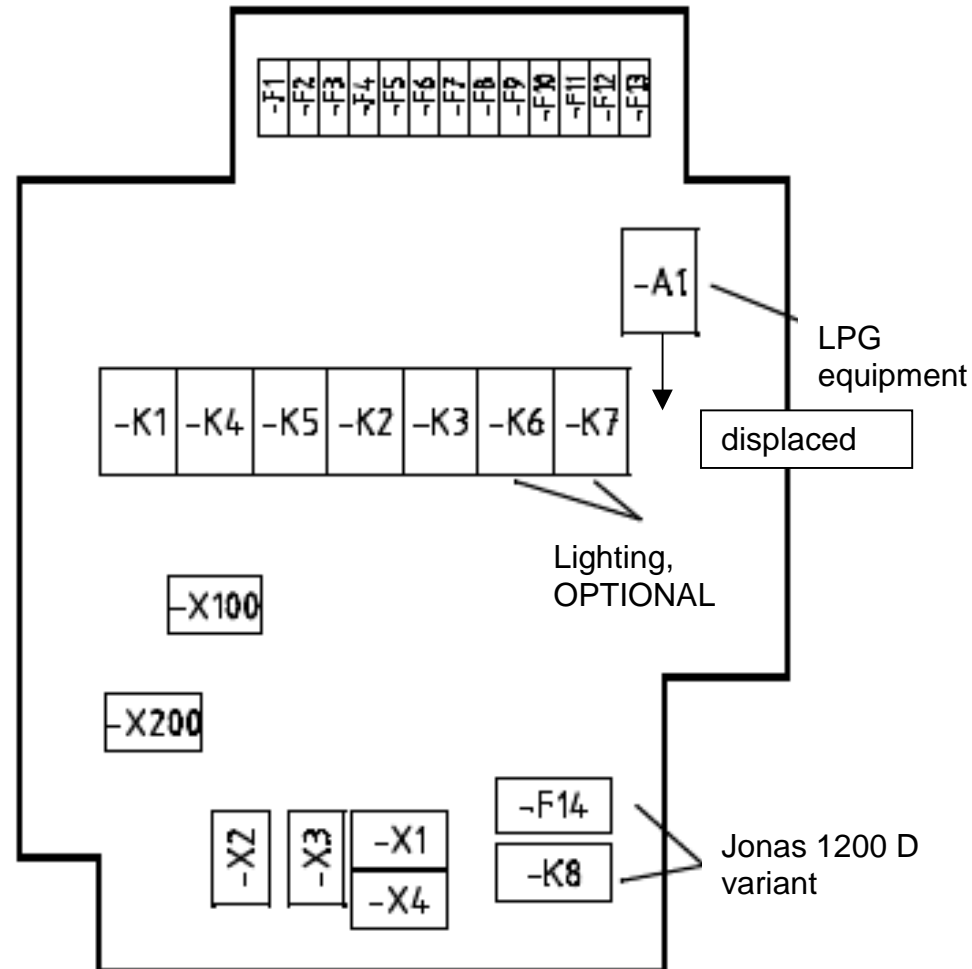

Pos	Description	LPG-Version	Diesel-Version
F1	Pre-fuse for key switch	15A	15A
F2	Fuse for K1 control voltage	5A	5A
F3	Fuse for K1/K5 control voltage	10A	10A
F4	Fuse for horn / pilot lamps	10A	10A
F5	Fuse for lighting, permanent plus	15A	15A
F6	Fuse for lighting, switched plus	10A	10A
F7	Fuse for parking / rear light, left-hand	5A	5A
F8	Fuse for parking / rear light, right-hand	5A	5A
F9	Fuse for jolter motor	35A	35A
F10	Fuse for direction indicator, left-hand	5A	5A
F11	Fuse for direction indicator, right-hand	5A	5A
F12	Fuse LPG (V) / pre-glowing control voltage (D)	10A	10A
F13	Fuse LPG (V) / post-heating control voltage (D)	10A	10A
F14	Main fuse for pre-glowing (D)	not assigned	30A
K1	Seat contact controller		
K2	Engine release relay		
K3	Starter relay		
K4	Time relay for pick-up delay / filter monitoring		
K5	Pulse relay for jolting		
K6	Relay for lighting	Optional	Optional
K7	Flashing relay	Optional	Optional
K8	Pre-glowing relay (D)	not assigned	
A1	LPG switch unit (V)	Optional	not assigned

6.3 View on E-Version Fuse Box

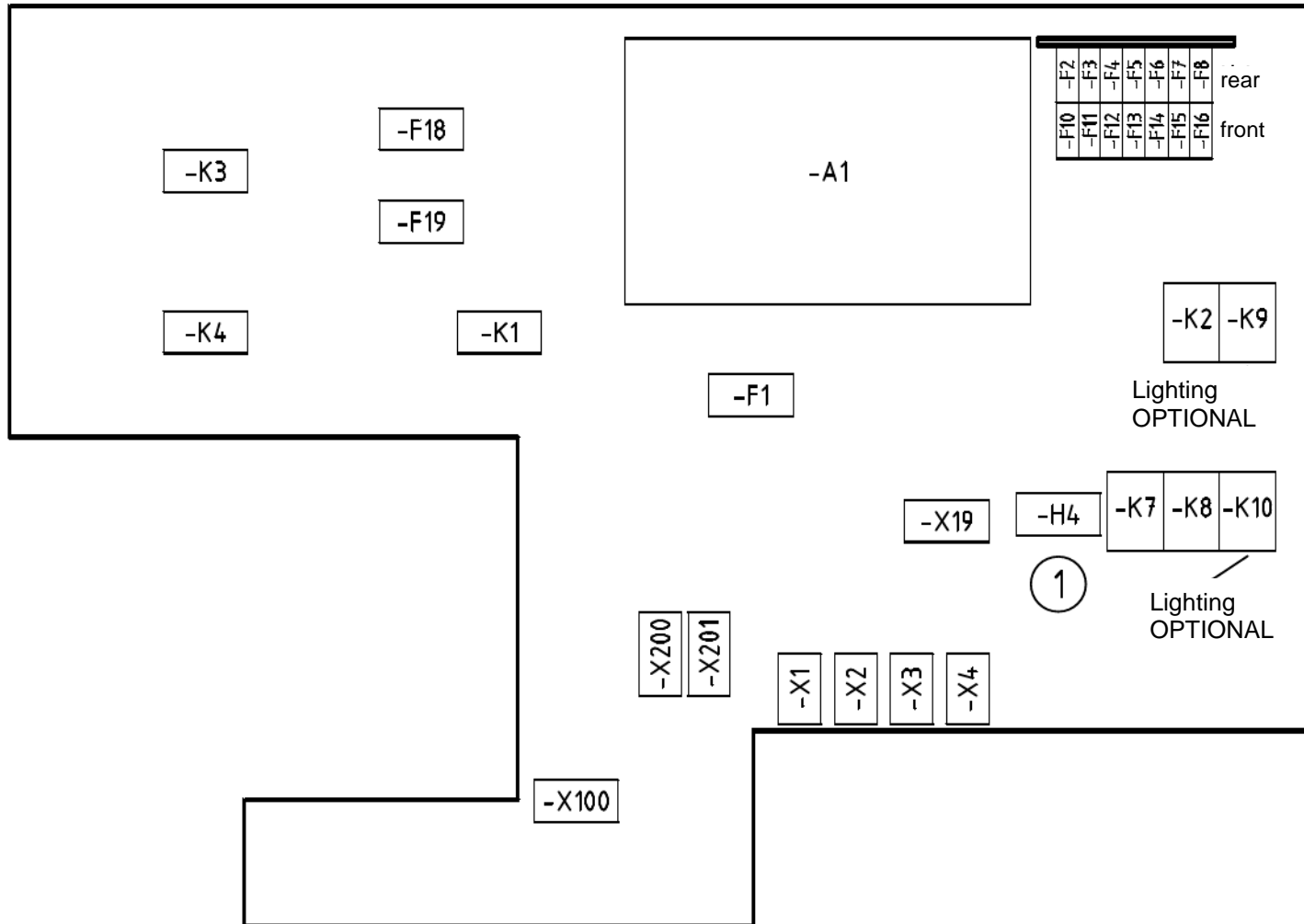

Pos	Description	E-Version
A1	Drive controller	
F1	Main fuse for drive controller	160A
F2	Fuse for start lock	15A
F3	Fuse for drive controller, switched plus	10A
F4	Fuse for LDS	5A
F5	Fuse for horn	7,5A
F6	Fuse for side brush motor, left-hand (optional)	2A
F7	Fuse for jolter activation	5A
F8	Fuse for vacuumer (optional)	30A
F10	Fuse for lighting, permanent plus	10A
F11	Fuse for lighting, switched plus	10A
F12	Fuse for parking / rear light, left-hand	5A
F13	Fuse for parking / rear light, right-hand	5A
F14	Fuse for flasher relay	10A
F15	Fuse for brake lights	7,5A
F16	Fuse for jolter pulse relay	35A
F18	Fuse for broom cylinder motor	63A
F19	Fuse for main motor	63A
H4	Warning horn	63A
K1	Main contactor for drive controller	
K2	Release of main motor	
K3	Relay of broom cylinder./ motor	
K4	Relay for main motor	
K7	Time relay for pick-up delay / filter monitoring	
K8	Pulse relay for jolting	
K9	Relay for working floodlight	Optional
K10	Flasher relay	

6.4 Seat Contact Controller

The S2 seat contact switch is monitored via the K1 relay which has implemented several logic functions.

6.4.1 Circuit Diagram

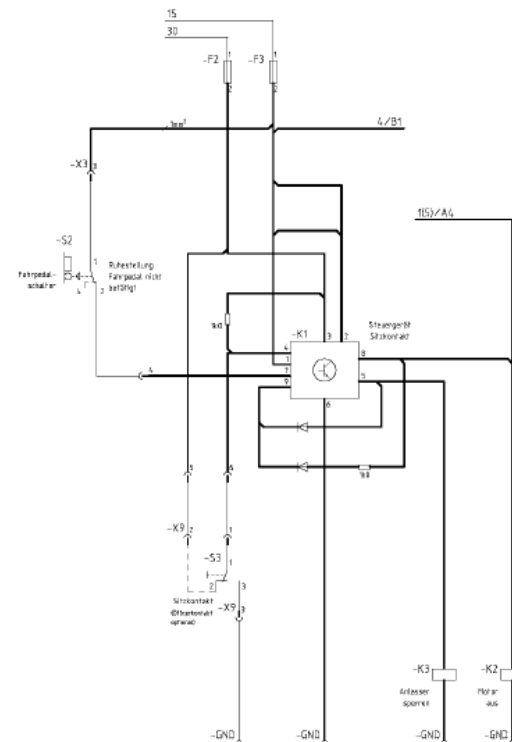

Wiring of Seat contact controller for Jonas 1200 V/D

6.4.2 Logic

Starting/Driving Safety Function

After ignition ON, 12V apply to PIN1 while simultaneously no voltage applies to PIN4 (seat contact closed) and the PIN8 output is connected. Voltage then applies to relay K2 (motor release). If, at the same time, 12V apply to PIN7 (accelerator pedal in neutral position), the PIN5 output will be connected. This allows supplying the relay K3 (starter) with current. If the seat contact is interrupted for 3 seconds or more (voltage at PIN4 to 12V), PIN8 output releases. This interrupts voltage supply to the release relay Riding (K2). If no voltage applies to the PIN4 input for 2 seconds or more, the PIN5 output will be switched off. This causes the starter relay (K2) to switch off.

Output Monitoring Safety Function

If voltage supply either at the PIN3 logic or at PIN2 supply breaks down, both outputs PIN 5+8 are switched off. The controller proceeds to a self-test directly after switching on (ignition ON) by first switching briefly on and off the PIN5 output and reading back via PIN9 input, followed by the PIN8 output. Should feedback to PIN9 be incorrect (internal error, external error: short-circuit behind plus), both outputs switch off.

Input Monitoring Safety Function

The PIN7 (neutral switch) and PIN4 (seat contact switch) inputs are permanently monitored. Should they be connected for 6 hours or longer (PIN4 no voltage; PIN7 12V) with simultaneous connection of PIN8 output, the next start trial will be inhibited. Actuation of the seat contact switch is required before resetting is available (even if neutral switch was the cause).

6.5 Drive Controller

The drive controller used in the Electric variant is a ZAPI controller of the type SEM1

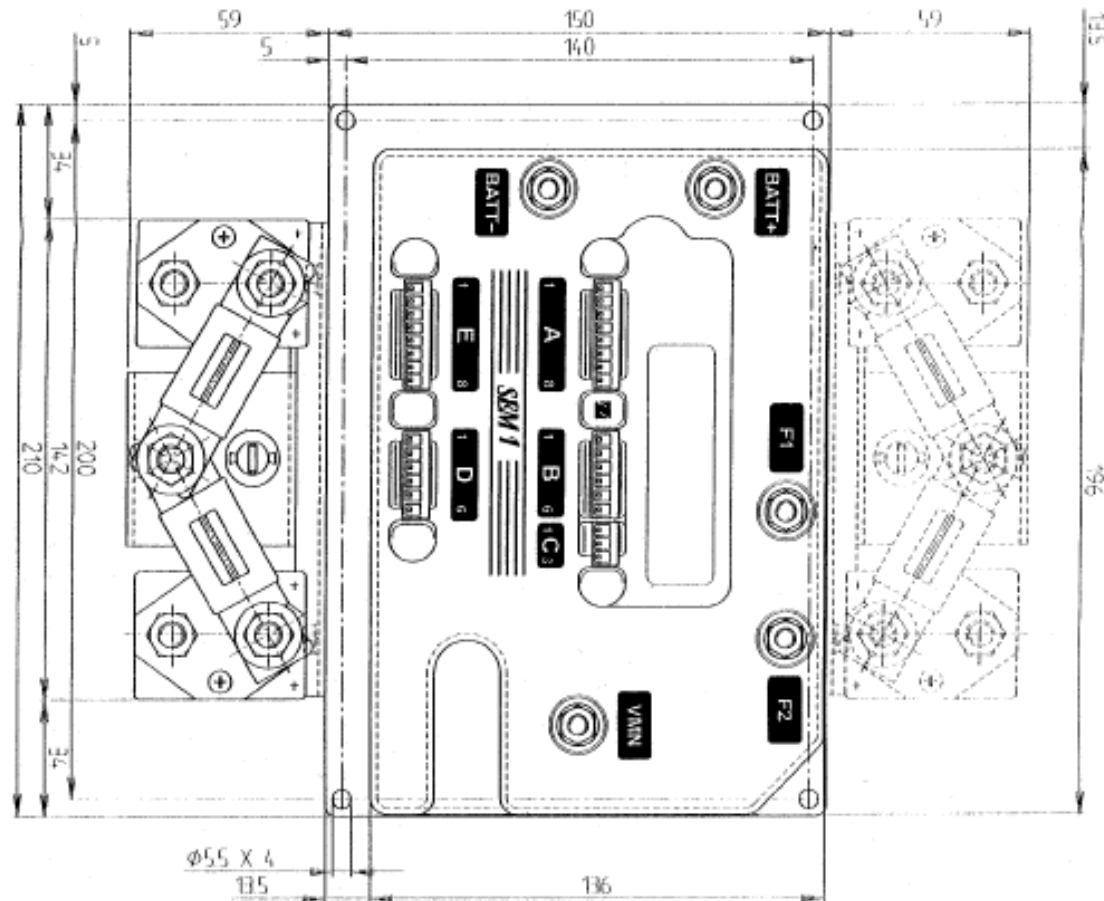

Monitoring functions realized via the controller.

Four sections are supervised:

- 1) Upon switching ON (key switch ON)
 - Self-test of controller
 - Current sensor
 - Power controller of drive motor
 - Contactor activation
 - Driving direction signal
 - Setpoint
- 2) Idle-circuit condition (ignition ON/no function)
 - Self-test of controller
 - Power controller of drive motor
 - Contactor activation
 - Current sensor
 - Setpoint
- 3) Driving
 - Self-test
 - Power controller of drive motor
 - Current for contactor activation
- 4) Continuously
 - Temperature of power unit
 - Battery voltage

Additionally the drive controller monitors some safety functions of the machine electric.

6.5.1 Error Messages

Errors are displayed via LED.

Flashing code	Error message	Description
1	LOGIC FAILURE #1	Error in the current monitoring at the main contactor
1	WATCH DOG	Error in the logic and/or program
1	EEPROM KO	Error in the area of the EEPROM
2	INCORRECT START	Error in the start sequence
2	FORW + BACK	Both travel drive directions apply simultaneously
3	CAPACITOR CHARGE	Error in the power unit
3	VMN NOT OK	Error during test of the drive motor power controller (armature circuit)
3	VFIELD NOT OK	Error of the field voltage
4	VACC NOT OK	Error of the accelerator pedal signal (potentiometer)
4	PEDAL WIRE KO	Error in the driving switch wiring
5	NO FIELD CURR	Error in the connection to field winding or in the current detection
5	HIGH FIELD CUR	Error in the connection to field winding or in the current detection
5	STBY I HIGH	Error in the armature current detection
5	I=0 EVER	Error in the armature current detection
6	CONTACTOR DRIVER	Error in the contactor activation
6	COIL SHORTED	Contactors coil short-circuited
6	CONTACTOR CLOSED	Error at main contactor contact
7	TH PROTECTION	Controller temperature exceeding limits (<70°C or > -10°C)

6.5.2 Machine Safety Functions

Main broom function

The PIN4 at plug A is only grounded if the following input signals are sended:

The key lock have to be switched "ON"; Signal on PIN2 at plug A have to be "HIGH"

The seat contact switch have to be activated; or max. 3 sec. Deactivated. Signal on PIN5 at plug A have to be "HIGH"

The LDS have to send a signal that the battery is not "LOW". Signal on PIN8 at plug A have to be "LOW"

Monitoring of start sequence

Driving will only be activated if firstly the key lock is "ON" and the seat switch is activated. PIN2 and PIN5 at plug A have to be "HIGH". Then a travel direction can be applied, by a "HIGH" signal at either PIN4 or PIN6 at plug B. Only if this sequence is done the travel will be working.

Monitoring of ignition key

If the key lock is "ON" and the seat switch is deactivated for longer then 3 sec. Then the following action is taken:

The ground for the main broom relay is switched "OFF". PIN4 at plug A is no longer grounded

The blower fan is switched "OFF". PIN1 at plug D is no longer grounded

The warning horn is activated. PIN1 at plug A is grounded

To reset the warning, the key lock have to be switched "OFF" and then "ON" again

Monitoring of seat switch

If the input at PIN 5 at plug A is "HIGH" for longer then 6 h then the following action is taken:

The ground for the main broom relay is switched "OFF". PIN4 at plug A is no longer grounded

The blower fan is switched "OFF". PIN1 at plug D is no longer grounded

The warning horn is activated. PIN1 at plug A is grounded

The driving speed is reduced to half speed. Internal signal in the drive controller.

To reset this, the key lock have to be switched "OFF" and "ON" again and then the seat switch have to be switched "ON" and "OFF"

6.6 Electric Drive Motor

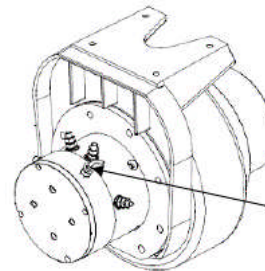
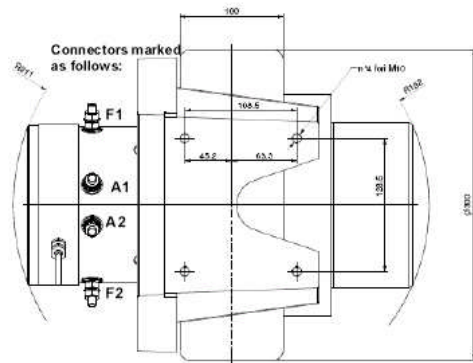
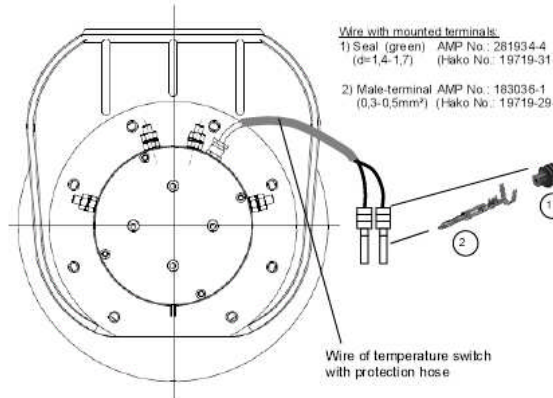
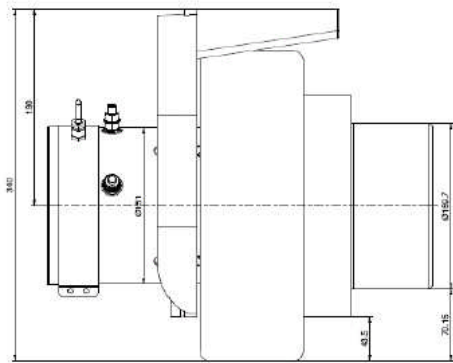

Technical Data

SEM motor

Type:	MR260/24V ECO
U _N :	24V
I _N :	76 A
P ₂ :	1500 W / S2 45min*
n _N :	3425min ⁻¹
torque _N :	4,2 Nm** (at I _N , U _N , I _{Field} = 12A)
Direction:	forwards / backwards
Efficiency:	ca. 0,82** (at I _N , U _N , I _{Field} = 12A)
Iso. cl.:	F
System of protection:	IP 54
Design:	wheel hub motor
Internal resistor _{Field} :ohm
Inductance _{Field} :
Internal resistor _{Armature} :ohm**
Inductance _{Armature} :
Electrical terminal:	M8 bolts (nuts and washer incl.)
Cooling:	surface cooling by air
Weight:	approxkg (incl. wheel)

equipped with

Temperature switch:	
Switch point:	120°C
Type:	NC
Terminal:	sealed AMP Super Seal Serie 1,5 (see drawing)
Wire length:	approx. 100 mm
Brush Type:	A24 Schunk
Durability:	approx. 1500 h***
Dimension:	9,8 x 19,9 x 26 (b x l x h)
Wheel Dimension:	300 x 100 mm
Material:	Polyurethane; white; non marking
Hardness:	82-85° Shore A

* data of manufacturer
 ** according to power diagram from manufacturer
 *** depend on operating

Note:
 modified Commutator d = approx. 62 mm
 modified brushholder

neutral

(without name of manufacturer or with with "Hako Group by Metalrota")

Type plate:		CE
Watt	1500	Duty S2/45min
Volt	24	Ins. cl. F
Amp.	76	IP 54
R.p.m.	3500	Tested date
Rot.		S/N
Type	151CA/ECO	Cod. M477
Gear ratio	30	
I _{Field} min 10 - max 25A, I _{Arm} 12A		
90529546		

6.7 Low Discharge Signal Sender (LDS)

Function of the low discharge signal sender is to safely protect the battery from low discharge while making full use of existing capacities.

Before taking the battery-powered machine into operation, set the low discharge signal sender (LDS) with combined battery charge indication to the battery type used in the machine.

Use of two battery types is admitted.

a) maintenance-free compound battery = **setting made in the factory**

b) low-maintenance tray battery

6.7.1 LDS Setting Mode

In order to create the setting conditions, switch on the machine and connect the configuration input of the LDS to battery plus. To do so, remove the false cover (a) from the operating panel and connect the plug contact underneath it. Now, programming of the LDS is possible.

Note:

After setting, make sure to disconnect the plugged contact again!

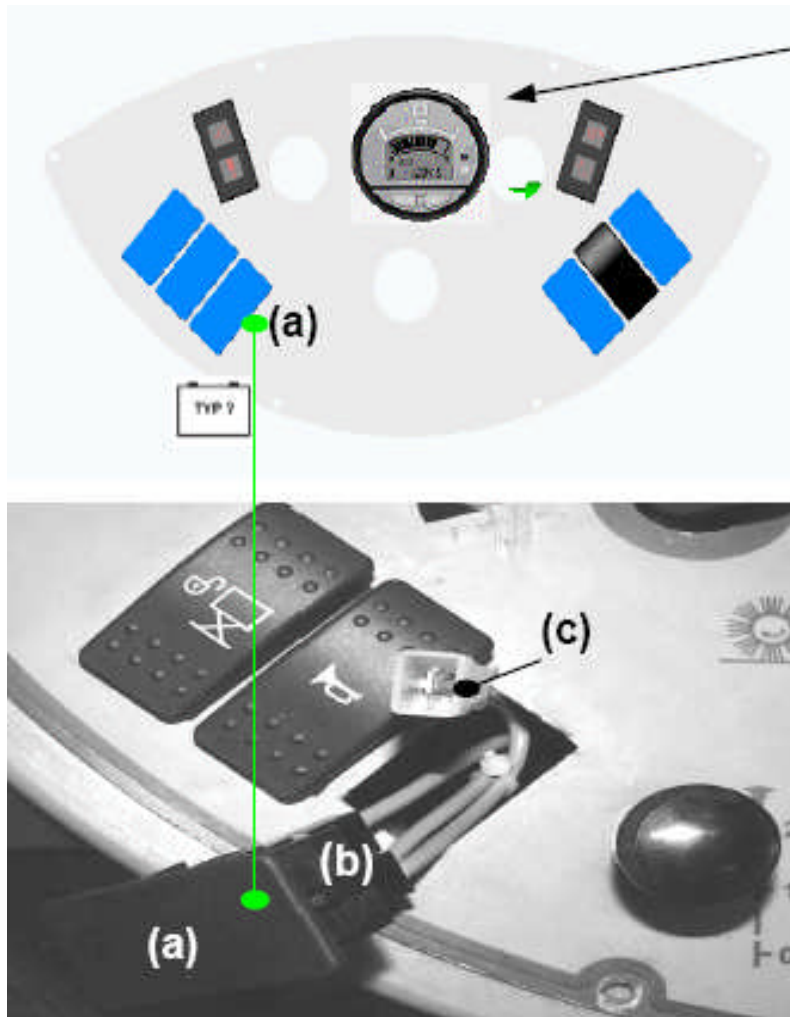

LDS with battery charge indication

- 1.) Remove false cover (a) from dashboard by prying out
- 2.) Pull plug contact (b) from false cover
- 3.) Connect plug contact (b) and tab connector (c)
- 4.) Proceed to LDS setting as described under 6.6.2
- 5.) After LDS setting, disconnect (b)+(c) again
- 6.) Connect plug contact (b) and false cover (a) again
- 7.) Re-insert false cover (a) into place

6.7.2 LDS Programming

In order to invoke the programming level, press the left button “▲/●” and hold depressed until display flashes. Then release button.



Set battery type:



In the display, three digits for the **discharge profile – charged** value are flashing (set to 2.04 V/Z in the factory). Press the right button “▶” to increment the charged value by 0.01 V/Z or hold depressed for continued incrementing. After the 2.30 V/Z value has been attained, display re-starts automatically with 1.80 V/Z. After the desired charged value of the profile has been attained, press the left button “▲/●” once.



In the display, three digits for the **discharge profile – discharged** value are flashing (set to 1.73 V/Z in the factory).

Press the right button “▶” to increment the discharged value by 0.01 V/Z or hold depressed for continued incrementing.

After the charged value has been attained, display re-starts automatically with 1.50 V/Z.

After the desired discharged value of the profile has been attained, press the left button “▲/●” once.

Terminate configuration mode by pressing the left button. Display then shows charge state.

After setting make sure to separate connection of plug contact in the dashboard.

Setting parameter:

Order-No	Type	Characteristic "charged"	Characteristic "discharged"
7401	4 x 6V battery GiV (240Ah)	2,04	1,76
7408	Tray Battery EPzS (420Ah)	2,04	1,73

7 Maintenance

7.1 LPG-Version Service Intervals

Service intervals	once after 50h	every 125 h	every 250 h	every 500 h
Change engine oil (type: SAE 15 W-40)	X	X	X	X
Change engine oil filter	X	X	X	X
Check engine speed	X		X	X
Check sealings at filter system	X	X	X	X
Visual check of V-belts	X			
Change hydraulic filter	X			X
Check hydraulic oil level	X	X	X	X
Check optical condition of machine	X	X	X	X
Change air filter		X	X	X
Check spark plug, replace if required	X	X	X	X
Check neutral centering of drive pump	X	X	X	X
Check service and parking brake, adjust if required	X	X	X	X
Check inflation pressure	X	X	X	X
Check sweeping track mark and adjust if required	X	X	X	X
Check brush apron and adjust or change if required	X	X	X	X
Check V-belt for wearing and correct tension and adjust if required	X	X	X	X
Basic cleaning of the plate filter	X	X		
Test drive and function test	X	X	X	X
Check battery			X	X
Check tension of steering chain and adjust if required			X	X
Check thread of wheels			X	X
Change plate filter			X	X
Check lifting-up disposal function (2-hand-operation)			X	X
Check hydraulic hoses and replace if required			X	X

Service Manual



Check cables and plugged connections for damage and tight fit			X	X
Change hydraulic oil				X
Engine; adjust valves				X
Engine, change valve cover seal				X
Safety checks				
Check fixing screws (brake, steering, lifting-up disposal) and tighten if required				X
Check brake system				X
Check steering function				X
Check LPG system for leaking and CO setting				X
Test drive and function test of safety relevant items				X

7.2 Diesel-Version Service Intervals

Service intervals	once after 50h	every 125 h	every 250 h	every 500 h
Change engine oil (type: SAE 15 W-40)	X		X	X
Change engine oil filter	X		X	X
Clean fuel filter	X			
Check engine speed	X		X	X
Check sealings at filter system	X	X	X	X
Visual check of V-belts	X			
Change hydraulic filter	X			X
Check hydraulic oil level	X	X	X	X
Check optical condition of machine	X	X	X	X
Change air filter		X	X	X
Check spark plug, replace if required	X	X	X	X
Check neutral centering of drive pump	X	X	X	X
Check service and parking brake, adjust if required	X	X	X	X
Check inflation pressure	X	X	X	X
Check sweeping track mark and adjust if required	X	X	X	X
Check brush apron and adjust or change if required	X	X	X	X
Check V-belt for wearing and correct tension and adjust if required	X	X	X	X
Basic cleaning of the plate filter	X	X		
Test drive and function test	X	X	X	X
Check battery			X	X
Check tension of steering chain and adjust if required			X	X
Check thread of wheels			X	X
Change plate filter			X	X
Check lifting-up disposal function (2-hand-operation)			X	X

Service Manual



Check hydraulic hoses and replace if required			X	X
Check cables and plugged connections for damage and tight fit			X	X
Change hydraulic oil				X
Change fuel filter				X
Engine; adjust valves				X
Engine, change valve cover seal				X
Safety checks				
Check fixing screws (brake, steering, lifting-up disposal) and tighten if required				X
Check brake system				X
Check steering function				X
Test drive and function test of safety relevant items				X

7.3 E-Version Service Intervals

Service intervals	once after 50h	every 125 h	every 250 h	every 500 h
Check sealings at filter system	X	X	X	X
Check wheel speed	X		X	X
Check broom speed	X		X	X
Visual check of V-belts	X			
Change hydraulic filter	X			X
Check hydraulic oil level	X	X	X	X
Check optical condition of machine	X	X	X	X
Check service and parking brake, adjust if required	X	X	X	X
Check sweeping track mark and adjust if required	X	X	X	X
Check brush apron and adjust or change if required	X	X	X	X
Check V-belt for wearing and correct tension and adjust if required	X	X	X	X
Basic cleaning of the plate filter	X	X		
Test drive and function test	X	X	X	X
Check battery		X	X	X
Check carbon brushes of drive motor and replace if required			X	X
Check carbon brushes of central motor and replace if required			X	X
Check tension of steering chain and adjust if required			X	X
Check thread of wheels			X	X
Change plate filter			X	X
Check lifting-up disposal function (2-hand-operation)			X	X
Check hydraulic hoses and replace if required			X	X
Check cables and plugged connections for damage and tight fit			X	X
Change hydraulic oil				X

Service Manual



Safety checks				
Check fixing screws (brake, steering, lifting-up disposal) and tighten if required				X
Check brake system				X
Check steering function				X
Test drive and function test of safety relevant items				X